

# Mori Seiki NT 4200-5400

Tool holder program

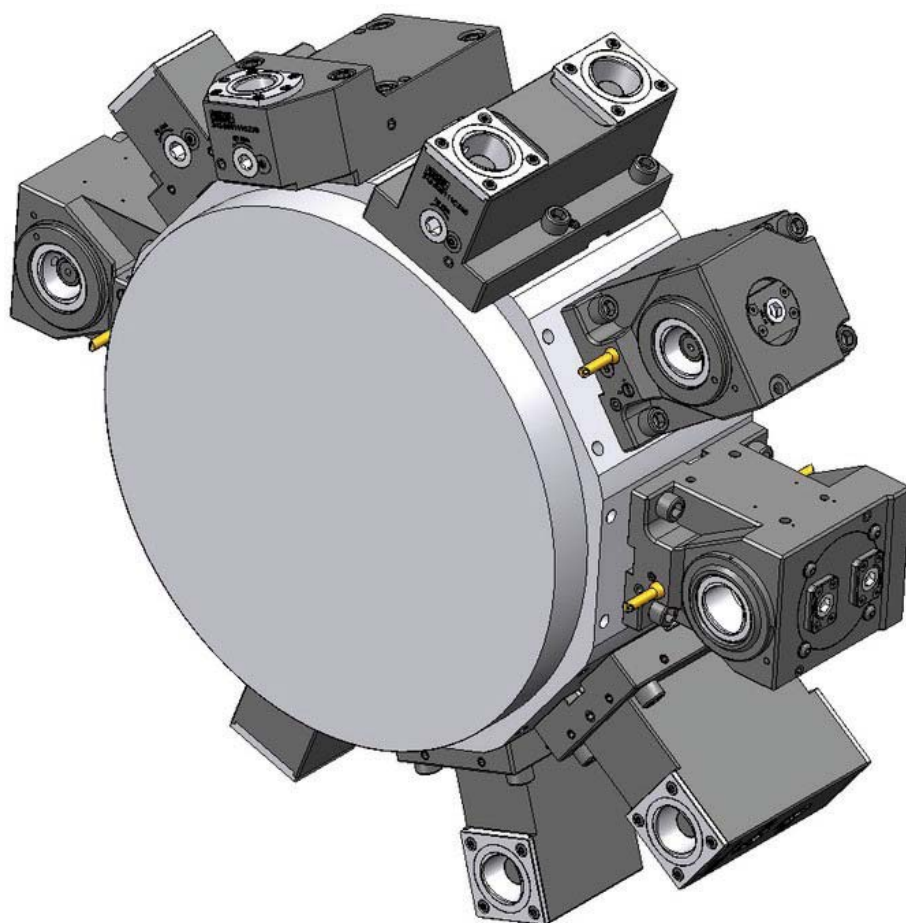

# Mori Seiki NT 4200-5400

Coromant Capto® Program



## OD clamping unit

C4	C4-TLE-MS60A (343-830111C107-RC)	Standard
C4	C4-TRE-MS60A (343-830111C107-LC)	Standard
C5	C5-TRE-MS60A (343-830111C104-RC)	Standard
C5	C5-TLE-MS60A (343-830111C104-LC)	Standard



## OD clamping unit, extended

C4	343-830111C270	Special
C5	343-830111C256	Special

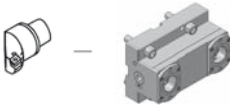

## OD clamping unit, both sides

C4	C4-TRE-MS60A-DT (343-830111C449-RC)	Standard
C4	C4-TLE-MS60A-DT (343-830111C449-LC)	Standard
C5	C5-TRE-MS60A-DT (343-830111C319-RC)	Standard
C5	C4-TLE-MS60A-DT (343-830111C319-LC)	Standard

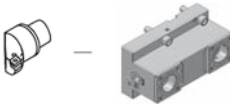

## OD clamping unit, both sides, extended

C4	343-830111C459	Special
C5	343-830111C320	Special

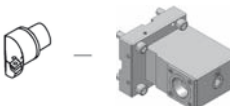

## Face and ID clamping unit, long

C4	343-830111C458	Special
C5	343-830111C203	Special

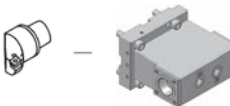

## Face and ID clamping unit, both sides, long

C4	343-830111C300	Special
C5	343-830111C202	Special

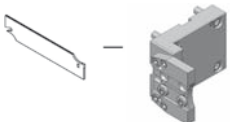

## Cut-off holder, adjustable

SH 32	APB-TNE-MS60A-25	Standard
-------	------------------	----------

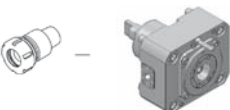

## OD drill/milling unit

C4	C4-DNE-MS60A-E	1:1	EC	Standard
C5	C5-DNE-MS60A-E	1:1	EC	Standard

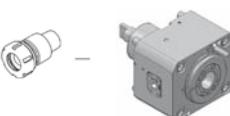

## OD drill/milling unit

C4	C4-DNE-MS60A-I	1:1	IC 80 bar	Standard
----	----------------	-----	-----------	----------

# Mori Seiki NT 4200-5400

Coromant Capto® Program

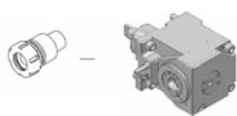

## Face drill/milling unit

C4	C4-DNI-MS60A-E	1:1	EC	Standard
C4	C4-DNI-MS60A-I	1:1	IC 80 bar	Standard
C5	C5-DNI-MS60A-E	1:1	EC	Standard
C5	C5-DNI-MS60A-I	1:1	IC 80 bar	Standard

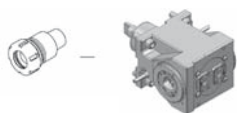

## Face drill/milling unit, both sides

C4	343-830820N1122	1:1	EC	Special
C5	343-830820N2467	1:1	EC	Special